

SMARTCORE[®] **COLOR LINEUP**

2021

SMARTCORE®

US PATENT # 8,196,221



TALBOT OAK
1329190



LANIER HICKORY
1329191



SHADY PINE
1329195



COWETA OAK
1329189



MONROE OAK
1329192



TIPTON OAK
1329188

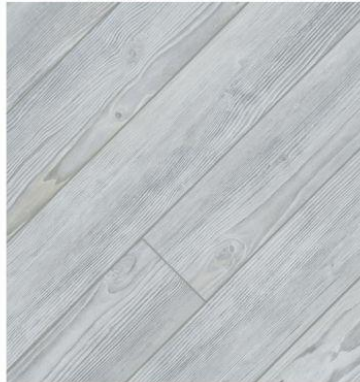

LINDEN PINE
1329193



BALDWIN OAK
1344175



CHATHAM STONE
1344179



SUMTER STONE
1344178



ARLINGTON OAK
3627529

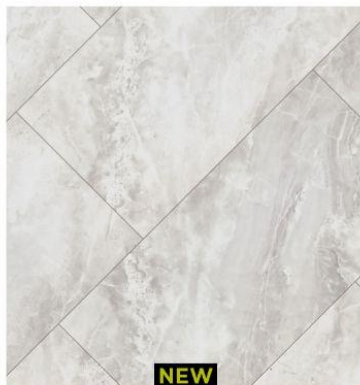

DESERT CANYON TILE
3627531



HALF MOON STONE
3627532



HANOVER HICKORY
3627528



HEARTHIDE HICKORY
3627530

SMARTCORE® *Ultra*

US PATENT # 9,104,283



BLUE RIDGE PINE
813596



WOODFORD OAK
813594



LEXINGTON OAK
813595



TIVOLI TRAVERTINE
784528



RICHMOND OAK
1035190



HUNTINGTON OAK
1035188



SAVANNAH OAK
1035196



FLORENCE TRAVERTINE
1035192

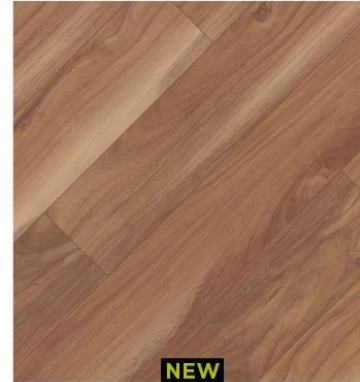

NEW
ADDINGTON ACACIA
3627536



NEW
CHAPARRAL OAK
3627533



NEW
MANDALAY MARBLE
3627539



NEW
MIDNIGHT ONYX MARBLE
3627538



NEW
PALMER STREET PINE
3627534



NEW
SABELLA MARBLE
3627537

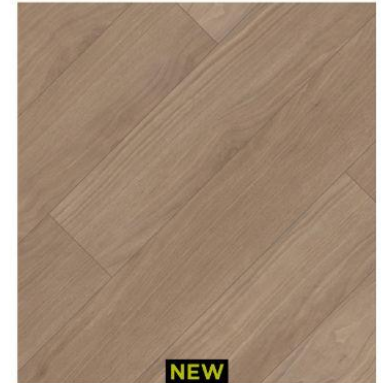

NEW
WESTGROVE WALNUT
3627535

SMARTCORE® *Ultra XL*

US PATENT # 8,338,232



SOUTHERN PECAN
1914825



SHERWOOD OAK
1914824



HARVEST HICKORY
1914822



WESTCHESTER WALNUT
1914826



CHADWICK OAK
1914823

SMARTCORE® PRO



BURBANK OAK
1035292



GARDENA MARBLE
1035296



CLAREMOUNT OAK
1035293



GLENDALE PINE
1035294



SUGAR VALLEY MAPLE
1035295



COVINGTON OAK
1035288



TOASTED EUCALYPTUS
1437478



JACKSON WHITE OAK
1035286



TWILIGHT
1035290



ASHLAND GRAY
1035297



ANDES GREYSTONE
3627544



CANOPY OAK
3627540



MORNING LIGHT MARBLE
3627543



OLD WHARF WALNUT
3627541



OXFORD OAK
3627542

SMARTCORE[®] Natural^{LS}



RIVERS EDGE OAK
1051334



CLIFFSIDE OAK
1051335



TIMBER CREEK OAK
1051337



STEPPING STONE OAK
1051338



BOULDER CREEK HICKORY
1051340



HAWKS CREST HICKORY
1051341



HOT SPRINGS HICKORY
1051342



SPRING CREEK BAMBOO
1051343



BLUEGRASS TRAIL MAPLE
1051339

THE SMART CHOICE FOR REAL WATERPROOF HARDWOOD

100% WATERPROOF FLOORING

1 REAL HARDWOOD FOR REAL LIFE

- Maintains its beauty even in the busiest homes
- Uniquely beautiful....no two planks are the same!

2 WATER? NO WORRIES

- 100% waterproof means no swelling, cracking or peeling when wet
- Install it anywhere - even kitchens, bathrooms, mudrooms, basements, laundry rooms and other wet areas

3 CLEANING IS A BREEZE

- Easy to clean and maintain
- Can even be damp mopped

4 EASY DIY-FRIENDLY INSTALL

- Click-together planks install in a snap over existing hard surface floors
- No adhesive or installation experience required

5 STRENGTH + STABILITY COME NATURALLY

- Hides most subfloor imperfections
- Won't expand or contract once installed



SMARTCORE Naturals



Traditional Hardwood

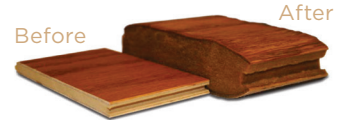

AVAILABLE IN:



HARDWOOD 5.00" w x Random Length
BAMBOO 5.12" w x Random Length



WHY SMARTCORE NATURALS?

KEY ● STANDARD ○ OPTIONAL

	SMARTCORE NATURALS	ENGINEERED HARDWOOD	TRADITIONAL HARDWOOD
100% WATERPROOF	●		
ADHESIVE-FREE DIY CLICK INSTALLATION	●	○	○
INSTALLS DIRECTLY OVER EXISTING HARD SURFACE FLOORS	●	○	
INSTALLS IN LARGE ROOMS WITHOUT TRANSITION STRIPS	●		
REQUIRES NO ACCLIMATION AND MINIMAL SUBFLOOR PREP	●		
HIDES SUBFLOOR IMPERFECTIONS	●	○	○
SUITABLE FOR LIGHT COMMERCIAL/HEAVY RESIDENTIAL TRAFFIC	●	○	○
GUARANTEED FOR 3 SEASON HOMES	●		
CAN BE INSTALLED ON ANY LEVEL OF THE HOME	●	○	

SMARTCORE NATURALS SPECS

100% WATERPROOF	✓
DIY CLICK INSTALLATION	✓
STRONG + STURDY CORE (SPC)	✓
BEVELED EDGES	✓
LIMITED LIFETIME RESIDENTIAL WARRANTY	✓
5 YEAR LIGHT COMMERCIAL WARRANTY	✓
SQUARE FEET PER CARTON	Hardwood: 20.01 sq.ft. Bamboo: 20.49 sq.ft.
PLANK SIZE	Hardwood: 5.00"w x Random Length Bamboo: 5.12"w x Random Length

SMARTCORE®

US PATENT# 9,156,233

FEATURING **COREtec** TECHNOLOGY

100% WATERPROOF. DIY-FRIENDLY INSTALL. EASY-TO-CLEAN.

PERFECT FOR ACTIVE FAMILIES WITH KIDS + PETS

1 PERFORMANCE WEAR LAYER 12 MIL

- Stands up to real life and then some, even rambunctious kids and rowdy pets
- Scratch, scuff, stain, and dent resistance

2 TRUE-TO-LIFE BEAUTY

- Unrivaled true-to-life beauty
- Wood and stone visuals
- Subtle bevel gives a clean, sleek look

3 SMARTCORE WPC CORE

- 100% waterproof - won't swell, crack or peel when exposed to water
- Rigid core hides most subfloor imperfections

4 ATTACHED ACOUSTICAL PAD

- Increases comfort and warmth underfoot
- Provides sound reduction

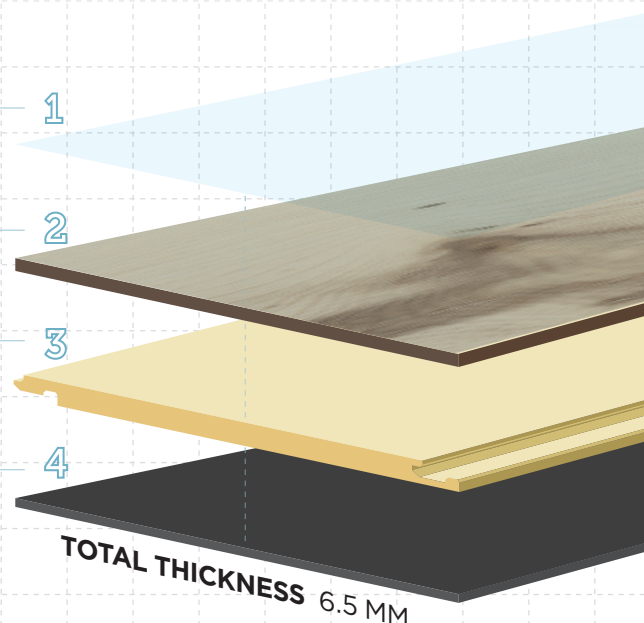

AVAILABLE IN:



A
CLEANER,
SMARTER
HOME

STARTS WITH
SMARTCORE®

IT'S MORE THAN JUST A PROMISE.

It's a commitment that our products will start clean, stay clean and be easy to clean.

STARTS CLEAN

No unnecessary additives.
Less is more!

STAYS CLEAN

Your floor is made in a manner that supports your goals for a clean, happy home.

EASY TO CLEAN

Designed to be easy to clean and care for, ensuring a long and healthy life for your flooring of choice.

MORE SMARTCORE® QUESTIONS? Call 1-800-355-7429 and select option 2 twice (Se habla español)

EXCLUSIVELY AT LOWE'S®

043021

WHICH SMARTCORE?	SMARTCORE [®]	SMARTCORE [®] <i>Ultra</i>	SMARTCORE [®] <i>Ultra XL</i>	SMARTCORE [®] PRO
100% WATERPROOF and PET-PROOF and KID-PROOF	✓	✓	✓	✓
DIY CLICK INSTALL	✓	✓	✓	✓
EASY TO CLEAN	✓	✓	✓	✓
ENHANCED DURABILITY <i>12 MIL WEAR LAYER</i>	✓	✓	✓	
COMMERCIAL-GRADE DURABILITY <i>20 MIL WEAR LAYER</i>				✓
BEVELED EDGES	✓			
ENHANCED BEVELED EDGES		✓	✓	✓
WOOD and STONE VISUALS	✓	✓		✓
ATTACHED ACOUSTICAL PAD	✓			
ENHANCED ATTACHED ACOUSTICAL PAD		✓	✓	✓
WARM and COMFORTABLE RIGID CORE (WPC)	✓	✓	✓	
STRONGER and STURDIER RIGID CORE (SPC)				✓
INSTALLS IN LARGE ROOMS WITHOUT TRANSITION STRIPS	✓	✓	✓	✓
LIMITED LIFETIME RESIDENTIAL WARRANTY	✓	✓	✓	✓
5 YEAR LIGHT COMMERCIAL WARRANTY	✓	✓	✓	
10 YEAR COMMERCIAL WARRANTY				✓
SQUARE FEET PER CARTON	Plank: 18.35 sq.ft. Tile: 19.63 sq.ft.	Plank: 15.76 sq.ft. Tile: 15.71 sq.ft.	Plank: 17.96 sq.ft.	Plank: 16.54 sq.ft. Tile: 15.83 sq.ft.
PIECES PER CARTON	Plank: 11 pieces Tile: 10 pieces	Plank: 8 pieces Tile: 8 pieces	Plank: 4 pieces	Plank: 7 pieces Tile: 8 pieces
PLANK / TILE SIZE	Plank: 5.00"w x 48.03" Tile: 11.97"w x 23.62"	Plank: 5.91"w x 48.03" Tile: 11.97"w x 23.62"	Plank: 8.97"w x 72.04"	Plank: 7.08"w x 48.03" Tile: 12.00"w x 23.74"

SMARTCORE® PRO

FEATURING **COREtec** TECHNOLOGY

100% WATERPROOF. DIY-FRIENDLY INSTALL. EASY-TO-CLEAN.

BUILT FOR THE MOST DEMANDING HOMES + SPACES

1 HIGH PERFORMANCE WEAR LAYER **20 MIL**

- Commercial-grade durability in the most demanding environments
- Extreme scratch, scuff, stain, and dent resistance
- Perfect for residential homes, light commercial, and multi-family

2 TRUE-TO-LIFE BEAUTY + TEXTURE

- Unrivaled true-to-life beauty and texture that looks and feels like the real deal
- Wood and stone visuals
- Enhanced bevel gives each plank dimension + depth

3 SMARTCORE SPC CORE

- 100% waterproof - won't swell, crack or peel when exposed to water
- Rigid core hides most subfloor imperfections
- Strong and stable even in extreme temperatures (-25°F to 155°F | -31.7°C to 68.3°C)

4 ATTACHED ACOUSTICAL PAD

- Underfoot comfort for high traffic spaces
- Reduces unwanted noise

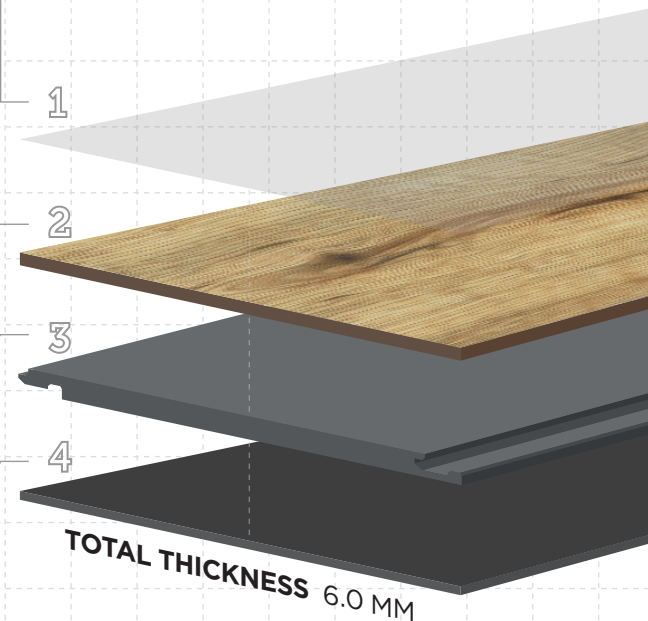

AVAILABLE IN:



**A
CLEANER,
SMARTER
HOME**

**STARTS WITH
SMARTCORE®**

IT'S MORE THAN JUST A PROMISE.

It's a commitment that our products will start clean, stay clean and be easy to clean.

STARTS CLEAN

No unnecessary additives.
Less is more!

STAYS CLEAN

Your floor is made in a manner that supports your goals for a clean, happy home.

EASY TO CLEAN

Designed to be easy to clean and care for, ensuring a long and healthy life for your flooring of choice.

MORE SMARTCORE® QUESTIONS? Call 1-800-355-7429 and select option 2 twice (Se habla español)

EXCLUSIVELY AT LOWE'S®

043021

WHICH SMARTCORE?	SMARTCORE [®]	SMARTCORE [®] <i>Ultra</i>	SMARTCORE [®] <i>Ultra XL</i>	SMARTCORE [®] PRO
100% WATERPROOF and PET-PROOF and KID-PROOF	✓	✓	✓	✓
DIY CLICK INSTALL	✓	✓	✓	✓
EASY TO CLEAN	✓	✓	✓	✓
ENHANCED DURABILITY 12 MIL WEAR LAYER	✓	✓	✓	
COMMERCIAL-GRADE DURABILITY 20 MIL WEAR LAYER				✓
BEVELED EDGES	✓			
ENHANCED BEVELED EDGES		✓	✓	✓
WOOD and STONE VISUALS	✓	✓		✓
ATTACHED ACOUSTICAL PAD	✓			
ENHANCED ATTACHED ACOUSTICAL PAD		✓	✓	✓
WARM and COMFORTABLE RIGID CORE (WPC)	✓	✓	✓	
STRONGER and STURDIER RIGID CORE (SPC)				✓
INSTALLS IN LARGE ROOMS WITHOUT TRANSITION STRIPS	✓	✓	✓	✓
LIMITED LIFETIME RESIDENTIAL WARRANTY	✓	✓	✓	✓
5 YEAR LIGHT COMMERCIAL WARRANTY	✓	✓	✓	
10 YEAR COMMERCIAL WARRANTY				✓
SQUARE FEET PER CARTON	Plank: 18.35 sq.ft. Tile: 19.63 sq.ft.	Plank: 15.76 sq.ft. Tile: 15.71 sq.ft.	Plank: 17.96 sq.ft.	Plank: 16.54 sq.ft. Tile: 15.83 sq.ft.
PIECES PER CARTON	Plank: 11 pieces Tile: 10 pieces	Plank: 8 pieces Tile: 8 pieces	Plank: 4 pieces	Plank: 7 pieces Tile: 8 pieces
PLANK / TILE SIZE	Plank: 5.00"w x 48.03" Tile: 11.97"w x 23.62"	Plank: 5.91"w x 48.03" Tile: 11.97"w x 23.62"	Plank: 8.97"w x 72.04"	Plank: 7.08"w x 48.03" Tile: 12.00"w x 23.74"

MORE SMARTCORE[®] QUESTIONS? Call 1-800-355-7429 and select option 2 twice (Se habla español)

EXCLUSIVELY AT LOWE'S[®]

SMARTCORE® *Ultra*

US PATENT# 9,156,233

FEATURING **COREtec** TECHNOLOGY

100% WATERPROOF. DIY-FRIENDLY INSTALL. EASY-TO-CLEAN.

HI-DEF VISUALS + MAXIMUM WARMTH + COMFORT

1 PERFORMANCE WEAR LAYER 12 MIL

- Everyday durability with more style and comfort
- Scratch, scuff, stain, and dent resistance

2 TRUE-TO-LIFE BEAUTY + TEXTURE

- Wood and stone visuals with hi-def beauty + texture
- High color variation for a dynamic look

3 SMARTCORE WPC CORE

- 100% waterproof - won't swell, crack or peel when exposed to water
- Rigid core hides most subfloor imperfections

4 PREMIUM ATTACHED ULTRASOFT® PAD

- Premium comfort and warmth underfoot
- Superior sound reduction

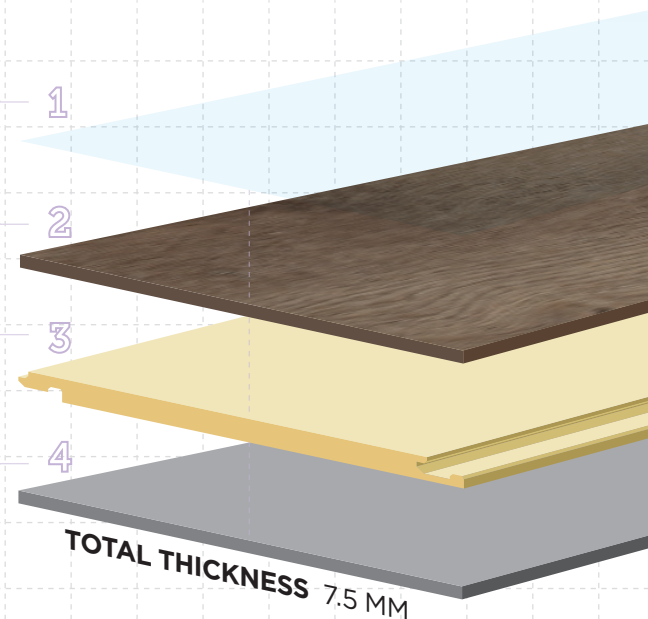

AVAILABLE IN:



A
CLEANER,
SMARTER
HOME

STARTS WITH
SMARTCORE®

IT'S MORE THAN JUST A PROMISE.

It's a commitment that our products will start clean, stay clean and be easy to clean.

STARTS CLEAN

No unnecessary additives.
Less is more!

STAYS CLEAN

Your floor is made in a manner that supports your goals for a clean, happy home.

EASY TO CLEAN

Designed to be easy to clean and care for, ensuring a long and healthy life for your flooring of choice.

MORE SMARTCORE® QUESTIONS? Call 1-800-355-7429 and select option 2 twice (Se habla español)

EXCLUSIVELY AT LOWE'S®

043021

WHICH SMARTCORE?	SMARTCORE [®]	SMARTCORE [®] <i>Ultra</i>	SMARTCORE [®] <i>Ultra XL</i>	SMARTCORE [®] PRO
100% WATERPROOF and PET-PROOF and KID-PROOF	✓	✓	✓	✓
DIY CLICK INSTALL	✓	✓	✓	✓
EASY TO CLEAN	✓	✓	✓	✓
ENHANCED DURABILITY <i>12 MIL WEAR LAYER</i>	✓	✓	✓	
COMMERCIAL-GRADE DURABILITY <i>20 MIL WEAR LAYER</i>				✓
BEVELED EDGES	✓			
ENHANCED BEVELED EDGES		✓	✓	✓
WOOD and STONE VISUALS	✓	✓		✓
ATTACHED ACOUSTICAL PAD	✓			
ENHANCED ATTACHED ACOUSTICAL PAD		✓	✓	✓
WARM and COMFORTABLE RIGID CORE (WPC)	✓	✓	✓	
STRONGER and STURDIER RIGID CORE (SPC)				✓
INSTALLS IN LARGE ROOMS WITHOUT TRANSITION STRIPS	✓	✓	✓	✓
LIMITED LIFETIME RESIDENTIAL WARRANTY	✓	✓	✓	✓
5 YEAR LIGHT COMMERCIAL WARRANTY	✓	✓	✓	
10 YEAR COMMERCIAL WARRANTY				✓
SQUARE FEET PER CARTON	Plank: 18.35 sq.ft. Tile: 19.63 sq.ft.	Plank: 15.76 sq.ft. Tile: 15.71 sq.ft.	Plank: 17.96 sq.ft.	Plank: 16.54 sq.ft. Tile: 15.83 sq.ft.
PIECES PER CARTON	Plank: 11 pieces Tile: 10 pieces	Plank: 8 pieces Tile: 8 pieces	Plank: 4 pieces	Plank: 7 pieces Tile: 8 pieces
PLANK / TILE SIZE	Plank: 5.00"w x 48.03" Tile: 11.97"w x 23.62"	Plank: 5.91"w x 48.03" Tile: 11.97"w x 23.62"	Plank: 8.97"w x 72.04"	Plank: 7.08"w x 48.03" Tile: 12.00"w x 23.74"

MORE SMARTCORE[®] QUESTIONS? Call 1-800-355-7429 and select option 2 twice (Se habla español)

EXCLUSIVELY AT LOWE'S[®]

SMARTCORE® *Ultra XL*

US PATENT# 9,156,233

FEATURING **COREtec** TECHNOLOGY

100% WATERPROOF. DIY-FRIENDLY INSTALL. EASY-TO-CLEAN.

WIDER + LONGER HI-DEF VISUALS + MAXIMUM WARMTH + COMFORT

1 PERFORMANCE WEAR LAYER **12 MIL**

- Everyday durability with more style and comfort
- Scratch, scuff, stain, and dent resistance

2 TRUE-TO-LIFE BEAUTY + TEXTURE

- Wood and stone visuals with hi-def beauty + texture
- High color variation for a dynamic look

3 SMARTCORE WPC CORE

- 100% waterproof - won't swell, crack or peel when exposed to water
- Rigid core hides most subfloor imperfections

4 PREMIUM ATTACHED ULTRASOFT® PAD

- Premium comfort and warmth underfoot
- Superior sound reduction

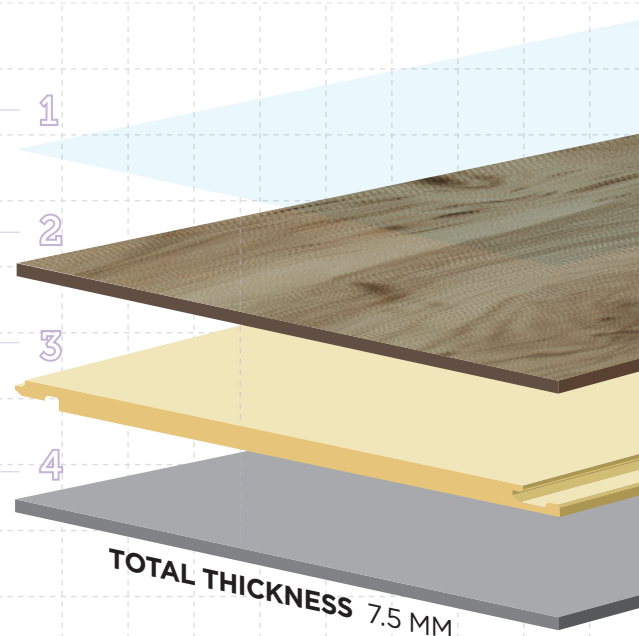

AVAILABLE IN:



WIDER + LONGER
PLANK 8.97" w x 72.04" l



A
**CLEANER,
SMARTER
HOME**

STARTS WITH
SMARTCORE

IT'S MORE THAN JUST A PROMISE.

It's a commitment that our products will start clean, stay clean and be easy to clean.

STARTS CLEAN

No unnecessary additives.
Less is more!

STAYS CLEAN

Your floor is made in a manner that supports your goals for a clean, happy home.

EASY TO CLEAN

Designed to be easy to clean and care for, ensuring a long and healthy life for your flooring of choice.

MORE SMARTCORE® QUESTIONS? Call 1-800-355-7429 and select option 2 twice (Se habla español)

EXCLUSIVELY AT LOWE'S®

043021

WHICH SMARTCORE?	SMARTCORE [®]	SMARTCORE [®] <i>Ultra</i>	SMARTCORE [®] <i>Ultra XL</i>	SMARTCORE [®] PRO
100% WATERPROOF and PET-PROOF and KID-PROOF	✓	✓	✓	✓
DIY CLICK INSTALL	✓	✓	✓	✓
EASY TO CLEAN	✓	✓	✓	✓
ENHANCED DURABILITY <i>12 MIL WEAR LAYER</i>	✓	✓	✓	
COMMERCIAL-GRADE DURABILITY <i>20 MIL WEAR LAYER</i>				✓
BEVELED EDGES	✓			
ENHANCED BEVELED EDGES		✓	✓	✓
WOOD and STONE VISUALS	✓	✓		✓
ATTACHED ACOUSTICAL PAD	✓			
ENHANCED ATTACHED ACOUSTICAL PAD		✓	✓	✓
WARM and COMFORTABLE RIGID CORE (WPC)	✓	✓	✓	
STRONGER and STURDIER RIGID CORE (SPC)				✓
INSTALLS IN LARGE ROOMS WITHOUT TRANSITION STRIPS	✓	✓	✓	✓
LIMITED LIFETIME RESIDENTIAL WARRANTY	✓	✓	✓	✓
5 YEAR LIGHT COMMERCIAL WARRANTY	✓	✓	✓	
10 YEAR COMMERCIAL WARRANTY				✓
SQUARE FEET PER CARTON	Plank: 18.35 sq.ft. Tile: 19.63 sq.ft.	Plank: 15.76 sq.ft. Tile: 15.71 sq.ft.	Plank: 17.96 sq.ft.	Plank: 16.54 sq.ft. Tile: 15.83 sq.ft.
PIECES PER CARTON	Plank: 11 pieces Tile: 10 pieces	Plank: 8 pieces Tile: 8 pieces	Plank: 4 pieces	Plank: 7 pieces Tile: 8 pieces
PLANK / TILE SIZE	Plank: 5.00"w x 48.03" Tile: 11.97"w x 23.62"	Plank: 5.91"w x 48.03" Tile: 11.97"w x 23.62"	Plank: 8.97"w x 72.04"	Plank: 7.08"w x 48.03" Tile: 12.00"w x 23.74"

MORE SMARTCORE[®] QUESTIONS? Call 1-800-355-7429 and select option 2 twice (Se habla español)

EXCLUSIVELY AT LOWE'S[®]